

EMITTING RADIATOR BASED ON LOW-TEMPERATURE HEAT PIPES

L. L. Vasil'ev and L. E. Kanonchik

UDC 536.423

We consider the design of a heat pipe-based emitting radiator used to remove heat from space objects and we investigate its behavior under steady and unsteady conditions. Experimental data obtained for an aluminum radiator point to a rather high efficiency at low temperatures and to the retention of performance capability after unfreezing.

The development of space technology requires the development and use of high-efficiency systems of thermal regulation. This is associated with an increase in heat generation aboard space vehicles, in the linear dimensions of the latter, and in the periods of their operation. Under conditions of reduced gravity it is impossible to use traditional heat exchangers or mechanisms of heat removal other than radiation. The quest for high power efficiency and self-containment predetermines the application of heat pipe (HP)-based emitting radiators.

In passing to minimum heat loading the danger of the freezing of the heat carrier in an HP arises, which may lead to serious difficulties upon a subsequent increase in heat generation. In view of this, it becomes highly topical to create improved radiators for heat-regulation systems of space vehicles that would be capable of attaining the working regime automatically from a frozen state. For this purpose it is necessary to know the laws of operation, the duration, and the possibilities for unfreezing HP-based radiators. The data available in the literature are insufficient for solving the problem posed.

Among the works on emitting radiators we should mention [1], in which an analysis of the trends of development is given and basic scientific-technical problems associated with the specific features of functioning in orbit are formulated.

In [2-5] separate structural details and technological aspects of the production of radiators and steady conditions of operation are described. In [2] a radiator of a new design is suggested, distinguished by enhanced reliability, speed of unfolding, and ease of maintenance. The cooling system consists of a set of identical panel elements with a power of 1-2 kW, each of which is 15.2 m long and 0.3-0.6 m wide. The basic element of the radiator is a powerful HP with axial trapeziform grooves. The width of a groove changes along its height from $1.8 \cdot 10^{-3}$ to $0.13 \cdot 10^{-3}$ m. For the most part, investigations were conducted to create and check an HP with axial grooves, and are virtually unconcerned with problems of operation of a radiator as a whole system.

In [3, 4] stainless steel HPs with a network, operating on ammonia, were used for radiators. In [5] a plane radiator on the basis of channel HPs is installed so that it could rotate around a central HP through a connecting module. This simultaneously satisfies the requirement of a large radiation surface formed by finned condensation zones of HPs. In some publications the possibility of freezing of a heat carrier in the HPs of a radiator is mentioned. In [6] it is recommended that freezing be avoided by using cryogenic HPs.

The trend of development of radiators with gas-controlled HPs is very promising. Attention was given to the solution of the problem of heat carrier freezing when radiators are shaded [7]. The radiator for heat-regulation of the equipment on the space station "Colombo" consisted of an aluminum panel with dimensions of 2.3×2.3 m and a radius of curvature of 2.2 m. Ammonia HPs connected by a Freon loop and a heat exchanger were mounted on the concave side, with the convex side being used for heat removal by radiation. Alternation of HPs of constant conductivity and gas-controlled HPs in the radiator made it possible to avoid the freezing-out of the heat carrier.

Academic Scientific Complex "A. V. Luikov Heat and Mass Transfer Institute of the Academy of Sciences of Belarus," Minsk. Translated from *Inzhenerno-Fizicheskii Zhurnal*, Vol. 67, Nos. 1-2, pp. 93-97, July-August, 1994. Original article submitted February 1, 1993.

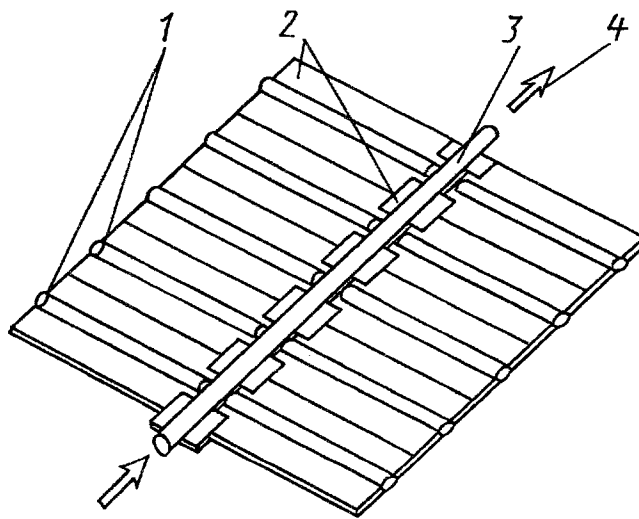

Fig. 1. Schematic diagram an emitting radiator on the basis of heat pipes: 1) HP; 2) plane fins; 3) channel; 4) gas.

In [8] a scheme for a low-temperature radiator is proposed in which the introduction of a noncondensing gas (nitrogen) into an HP together with ammonia and the heating of the HP reservoirs are provided for in order to avoid freezing. A multilayered wick made of metal network is provided for creating capillary head.

Additional electric heaters were also used in the reservoirs of gas-controlled HPs during the operation of a space telescope [9] within the temperature range 260-320 K. The radiator contained six aluminum HPs of length 2.29 m filled with ammonia and nitrogen.

The use of special electric heaters leads to additional energy expenditures and an increase in mass and it decreases the degree of reliability of the whole system. Moreover, the introduction of a noncondensing gas into an HP causes blockage of a portion of the condenser and a decrease in the power removed.

In the present paper we consider the design of an emitting radiator (Fig. 1) intended for operation at low temperatures. The radiator consists of a central channel for gas or liquid (possibly a high-efficiency heat pipe) 0.022 m in diameter on which HPs with plane fins of half-width 0.052 m are installed. The radiating surface is formed by 10 HPs of length 0.3 m and diameter 0.016 m that are welded to the channel along the finning. This is possible because the channel and the HPs were produced by extension moulding from a monolithic aluminum section with 0.0017-m-thick longitudinal fins.

To duplicate radiation fins, channel HPs were selected. As shown in [10], they are less sensitive to the degree of filling with liquid and can unfreeze independently due to the axial thermal conductivity of the container and transfer of the latent heat of vaporization. On the internal side of the HP container 28 longitudinal square open grooves are made with a side equal to 0.0005 m.

In laboratory investigations the heat carrier was Refrigerant-113, the temperature of the triple point of which is equal to 236.4 K. The heat pipes are also intended for operation under natural conditions on ammonia and acetone, depending on the working temperature.

Experiments were conducted on the setup whose schematic diagram is given in Fig. 2. It includes the following basic elements: working chamber; vacuum and forevacuum collectors; systems for heat supply, evacuation, water supply, and electric-power supply; nitrogen tank; instrumentation unit. Inside the chamber there are a fastening device and a platform that ensure the placing of the radiator in a horizontal or inclined position. The supports and stands are insulated from the object of investigation with foam plastic, and the fasteners are insulated with Teflon. Cryogenic screens connected by a single nitrogen circuit have the dimensions 2×1 m. They are installed at a distance of 0.1–0.5 m from the object of investigation. The cryogenic screens are protected from radiation from the side of the chamber walls with the help of several layers of metal foil. In the working chamber, conditions similar to those in space are simulated: a vacuum of 0.013 Pa and a temperature of the nitrogen screens equal to 103 K.

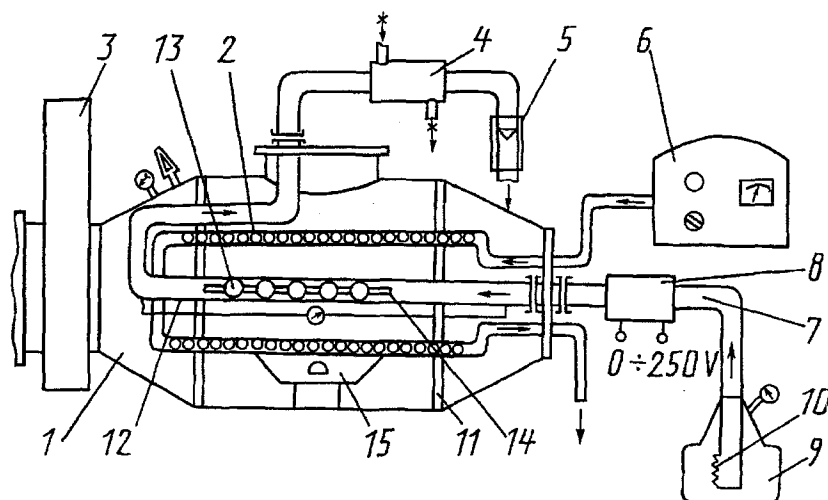

Fig. 2. Schematic diagram of the experimental setup: 1) chamber; 2) cryogenic screens; 3) slide gate; 4) liquid heat exchanger; 5) gas flowmeter; 6) nitrogen tank; 7) gas path; 8) regulated electric heater; 9) Dewar flask; 10) electric heater; 11) fastening device; 12) gas channel; 13) HP; 14) plane fins; 15) platform.

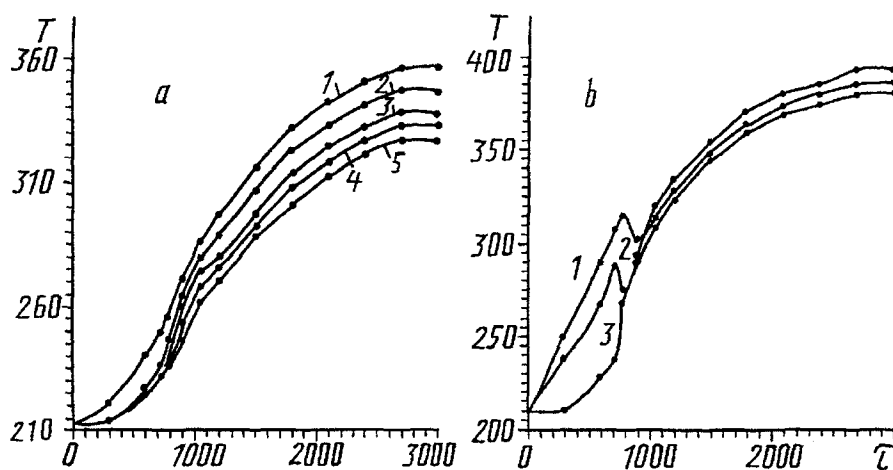

Fig. 3. Dynamics of the change in temperature in the process of unfreezing of an emitting radiator with low-temperature heat pipes: a) sections (1-5 are the numbers of the sections in the direction of motion of the gas flow); b) a separate HP: 1) evaporator; 2) adiabatic zone; 3) condenser; $G = 0.004$ kg/sec; $T_g = 489$ K. T , K; τ , sec.

The experimental procedure provided preliminary freezing of the radiator, its subsequent start-up, and attainment of steady-state conditions of operation.

During the tests, the temperature fields were measured with copper-constantan thermocouples, whose heads were imbedded in the container of one of the HPs, along the channel and along the edge of the fins. Their readings with a maximum absolute error of 0.07 K were recorded by a measuring system consisting of an F799/1 commutator, Shch68003 digital voltmeter, and Shch6800K numeric printer.

The heat flux supplied to the radiator was determined by measuring the volumetric flow rate and the change in the enthalpy of the gas (nitrogen) in the channel.

The emitting radiator was cooled by heat removal by radiation to the nitrogen screen. It was regarded frozen when the temperature of the fins of the radiating surface was below the triple point of the R-113 (236.4 K), which guaranteed the transition of the working liquid in an HP to the solid phase.

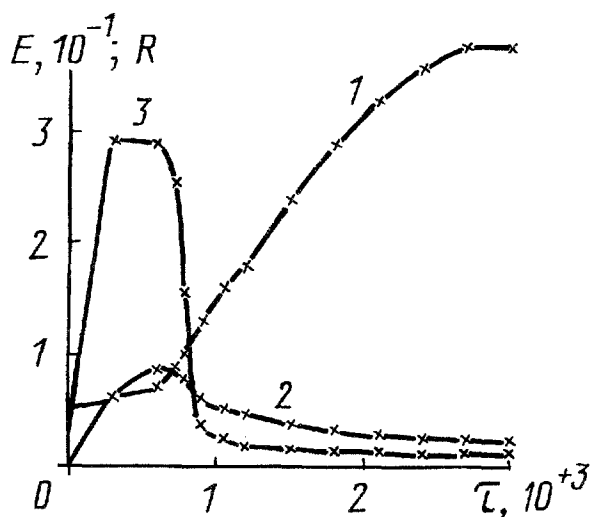

Fig. 4. Dependence of the efficiency (1), thermal resistance of the radiator (2), and thermal resistance of an HP (3) on time in the process of unfreezing of the emitting radiator; $G = 0.004$ kg/sec; $T_g = 489$ K. E, R , W/K.

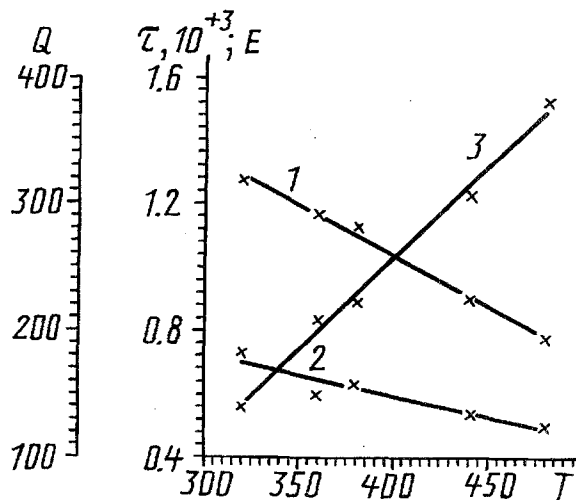

Fig. 5. Dependence of the time of unfreezing (1), efficiency (2) and heat removal from the emitting radiator (3) on the temperature of the gas entering the channel; $G = 0.004$ kg/sec. E, Q , W.

As a result of experimental investigations, we obtained data on the stationary and dynamic characteristics of the radiator during the freezing-unfreezing cycle for different temperatures (322, 364, 384, 445, 489 K) of the gas entering into the channel and a flow rate equal to 0.004 kg/sec.

In Fig. 3a typical dynamic characteristics of the radiator obtained in the process of unfreezing for gas temperature of 489 K are given. The hot gas caused successive warming up of the radiator sections in the direction of gas motion. From the dynamics of the change in temperature it is seen that the front of the temperature equal to the triple point reached the first section 537 sec after the start-up and the fifth section 945 sec. This is explained by the cooling of the gas, which, while moving, transfers a portion of the heat to the channel wall.

The start-up characteristics of a refrigerant HP, which duplicates a fin, are presented in Fig. 3b. We observed the start-up of the HP and attainment of a steady-state regime of operation with complete melting of the heat carrier in all the zones. A short length and high thermal conductivity of the container produced favorable conditions for heating without the freezing of the vapor. The pattern of change of the temperature field of the channel HP as a component of the radiator is similar to the start-up of an ammonia HP from the state with the heat carrier frozen in its condenser [11] in the case of heat supply under boundary conditions of the third kind and heat removal by radiation. One should note a typical fall in temperature corresponding to the return of the melted heat carrier to the evaporation zone, as well as an appreciable nonisothermality of the container along its length in the process of unfreezing.

The restoration of the closed circulation of heat carrier caused the fall of the thermal resistance of the HP (Fig. 4). The thermal resistance of the radiator decreased with time more smoothly than with a single HP, which was caused by sequential start-up of 10 HPs.

To obtain experimental justification for the performance capability of the radiator after unfreezing, let us analyze the change in time of a characteristic of the radiator such as the efficiency, which is equal to the ratio of the flux removed by radiation to the heat flux emitted by an isothermal radiator at the temperature of the gas at the entrance to the channel (Fig. 4). We may isolate three characteristic periods in the process of the start-up of the radiator. In the period $\tau \leq 537$ sec unsteady-state heating of the sections up to the triple point takes place, with HPs not operating. With the hot gas, the heat from the channel is transferred by axial heat conduction through the container of the pipes and through the fins. The efficiency of the radiator is low. In the second period $537 < \tau \leq 945$ sec, the sections are unfrozen and they are successively included in operation. The efficiency undergoes

quantitative and qualitative changes caused by the start-up of the HP. The warming-up of the structure is intensified at the expense of heat transfer in an HP by the latent heat of vaporization. In the third period the radiator is warmed up to the working temperature, and the efficiency tends to a constant value.

The increase in the gas temperature from 322 to 489 K ensures, on the one hand, an increase in the heat removal from a five-section emitting radiator from 150 to 500 W and accelerates the process of unfreezing. On the other hand, in this case one observes a decrease in the efficiency of heat removal from the radiator (Fig. 5).

Thus, the main results of the work are the experimentally established laws governing unfreezing and attainment of the working regime in an emitting radiator on the basis of low-temperature HPs within the temperature range 103–493 K. The proposed design for a radiator for removing heat from space objects is rather efficient at low temperatures and at the same time is relatively simple from the viewpoint of the technology of manufacture. The reliability of the emitting radiator as regards the problem of its start-up from a frozen state is confirmed experimentally.

REFERENCES

1. A. A. Nikonov, G. A. Gorbenko, and V. N. Blinkov, *Heat Exchanging Circuits with a Two-Phase Heat Carrier for Thermal Regulations of Space Apparatus* [in Russian], Moscow (1991).
2. R. F. Richter, P. T. Brennan, and J. G. Rankin, *AIAA Paper*, No. 1342, 1-8 (1986).
3. A. W. Carlson and E. Gustafson, *AIAA Paper*, No. 1300, 1-7 (1985).
4. M. A. Merrigan, E. S. Keddy, and J. T. Sena, *AIAA Paper*, No. 1273, 1-8 (1986).
5. M. M. Amidiev, B. Moschetti, and M. B. Tatry, *Proc. 6th Int. Heat Pipe Conf. (Grenoble, 1987)*, Vol. 1, pp. 274-279 (1987).
6. N. H. Pennings and C. J. Savage, *Proc. 6th Int. Heat Pipe Conf. (Grenoble, 1987)*, Vol. 3, pp. 251-263 (1987).
7. G. Racca and L. Costamagna, *Proc. 6th Int. Heat Pipe Conf. (Grenoble, 1987)*, Vol. 3, pp. 268-273 (1987).
8. Han Hwangbo, *Proc. 13th Int. Symp. Space Technol. and Scien. (Tokyo, 1982)*, pp. 62-66 (1982), pp. 62-66 (1982).
9. I. Alet, *Proc. 6th Int. Heat Pipe Conf. (Grenoble, 1987)*, pp. 329-332 (1987).
10. L. E. Kanonchik, *Investigation of Radiative Panels Based on Low-Temperature Heat Pipes*, Author's Abstract of Candidate's Dissertation, Minsk (1992).
11. L. E. Kanonchik, P. I. Sergeev, and A. A. Orlov, in: *Heat Pipes and Heat Exchangers: From Science to Practice* [in Russian], Minsk (1990), pp. 106-111.